

Sony Wide TV System ICs Offering Simple System Configuration Auto-Wide, Y/Chroma/Deflection Processing ICs, Video Switch

CXA2000Q, CXA2040Q, CXA2050S, CXD2053AS

Wide-format TVs offering large, clear pictures are now becoming the norm in Japan. They are also enjoying a similar popularity in Europe and other areas, with more and more people switching to the wide format since the advent of the PAL+ system.

Sony led the way with the release of the highly-rated CXA2025AS NTSC Y/chroma/deflection processing IC. Next to be released is the much-anticipated CXA2000Q NTSC/PAL version, introduced here together with the CXD2053AS auto-wide discrimination IC and the CXA2040Q video switch. These ICs offer a simple wide-format system that is exactly right for the times.

- I²C bus^{*1} support
- PAL/NTSC support (CXA2000Q/CXA2050S)
- Skirt support (CXA2040Q)

*1 For I²C bus:
Buyers who purchase parts designed for the Sony I²C bus receive the right to use them carrying the Philips Corporation's patent in systems which conform to the I²C bus standard specification set by Philips Corporation.

*2 OSD: On-screen display

■ System Configuration Using a Small Number of Components

Using only the CXA2000Q, CXD2053AS, and CXA2040Q, it is possible to configure a wide TV signal processing system with five-composite-input and two-Y/C-input capability, skirt support, and a built-in auto-wide function.

■ PAL/NTSC Compatible CXA2000Q

The CXA2000Q inherits the features of the CXA2025S and therefore, once picture distortion adjustment has been performed in full-mode, it need not be performed in the various wide modes. In other words, wide TV support is provided, there are few external components, and wide function adjustment on the production line is greatly reduced. Also, support for non-interlace OSD^{*2} display provides flicker-free display of text. PAL and NTSC systems are supported, and support for SECAM can also be provided by connecting a SECAM decoder. Two RGB inputs are also supported (one of which has dual analog/digital capability). A 64-pin QFP surface-mount package is used, offering an excellent space factor.

■ CXA2050S, Sister Chip to the CXA2000Q

The CXA2050S features a different package and some differences in functions from the CXA2000Q. The functional features at left are the same in both products. The main differences are as follows:

- Easy-to-handle 64-pin SDIP package
- VIDEO OUT pin provided
- P in P Y/color difference input supported
- Switchable SHP fo
- Switchable VM level
- High-speed channel switching mode supported
- Independent upper/lower corner pins
- Fixed SCP burst gate pulse phase
- Different killer level, YM level, OSD level

■ CXA2040Q Video Switch with Skirt Support

A SYNC ID function is provided for the input (CV system), making this IC suitable for PAL use. Optimal input coverage is provided—five composite video inputs and three outputs, and two Y/C (S terminal) inputs and one output.

V O I C E

Designers rose up with a cry of "It has to change!", cherishing in their hearts dreams and aspirations that claim "There is only one world, and all men a brothers."

A little later, small but promising ICs uttered their first sounds in the depths of space so that wide TV could be readily enjoyed in various countries. We hope you will join in the rearing process.

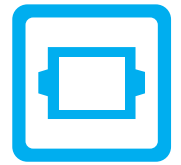

*New
Products*

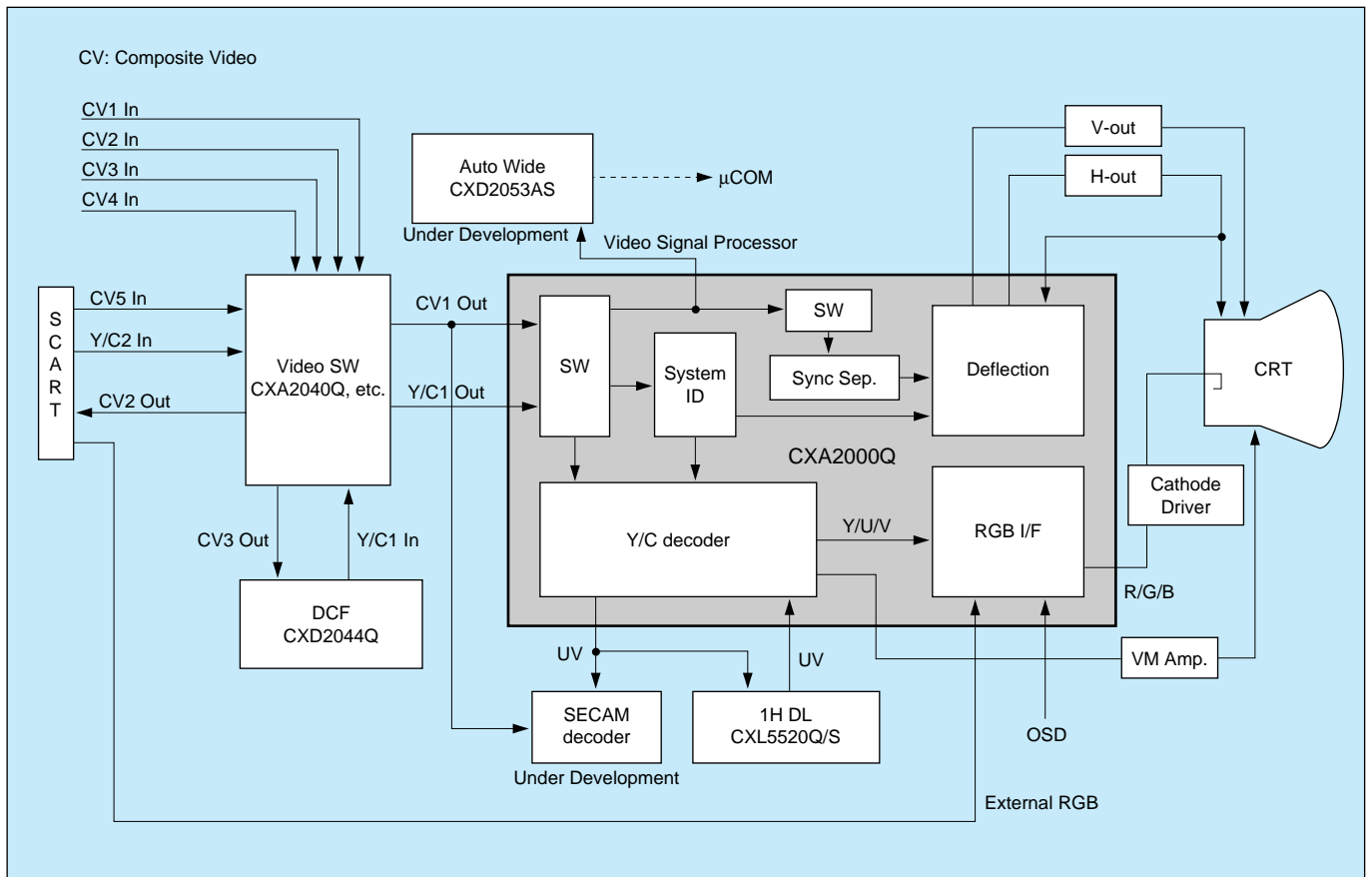

Figure 1 Multisystem TV Block Diagram